

MODEL

H 60KA

HITACHI
POWER TOOLS

HAMMER
H 60KA

TECHNICAL DATA
AND
SERVICE MANUAL

H

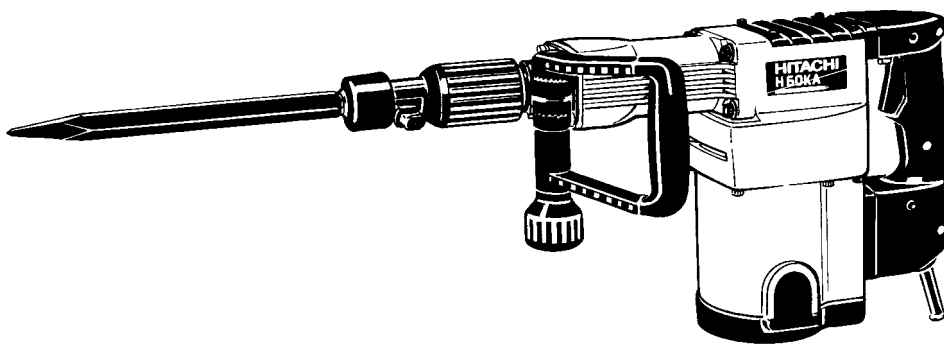

LIST No. E458

Jun. 2000

SPECIFICATIONS AND PARTS ARE SUBJECT TO CHANGE FOR IMPROVEMENT

Notice for use

Specifications and parts are subject to change for improvement.
Refer to Hitachi Power Tool Technical News for further information.

CONTENTS

	Page
1. PRODUCT NAME	1
2. MARKETING OBJECTIVE	1
3. APPLICATIONS	1
4. SELLING POINTS	1
4-1. Selling Point Descriptions	2
5. SPECIFICATIONS	3
5-1. Optional Accessories	4
6. COMPARISONS WITH SIMILAR PRODUCTS	5
6-1. Specification Comparisons	5
6-2. Demolition Performance	5
7. PRECAUTIONS IN SALES PROMOTION	6
7-1. Handling Instructions	6
7-2. Caution Plate	6
7-3. Grease Replacement	6
7-4. O-Ring Replacement	6
8. REFERENCE INFORMATION	7
Structure:	7
8-1. Striking Operation	7
8-2. Idling-Proof Mechanism	8
8-3. Sealed and Dustproof Construction	8
8-4. Vibration Absorbing Construction	9
8-5. Tool Retainer (Fig. 7)	9
8-6. Side Handle	10
9. REPAIR GUIDE	11
9-1. Precautions and Suggestions for Disassembly and Reassembly of the Main Body	11
9-1-2. Reassembly	12
10. STANDARD REPAIR TIME (UNIT) SCHEDULES	18
Assembly Diagram for H 60KA	19

1. PRODUCT NAME

Hitachi Electric Hammer, Model H 60KA

2. MARKETING OBJECTIVE

As a high-end electric hammer, the Model H 60KA joins the shank-type series with the current Model H 55SA to target the European markets. With this product series, we aim to enhance the share of the hammer market using KANGO 21-mm accessory tools.

3. APPLICATIONS

- Demolishing and chiseling of concrete
- Edging, grooving, cutting, stripping, etc.

4. SELLING POINTS

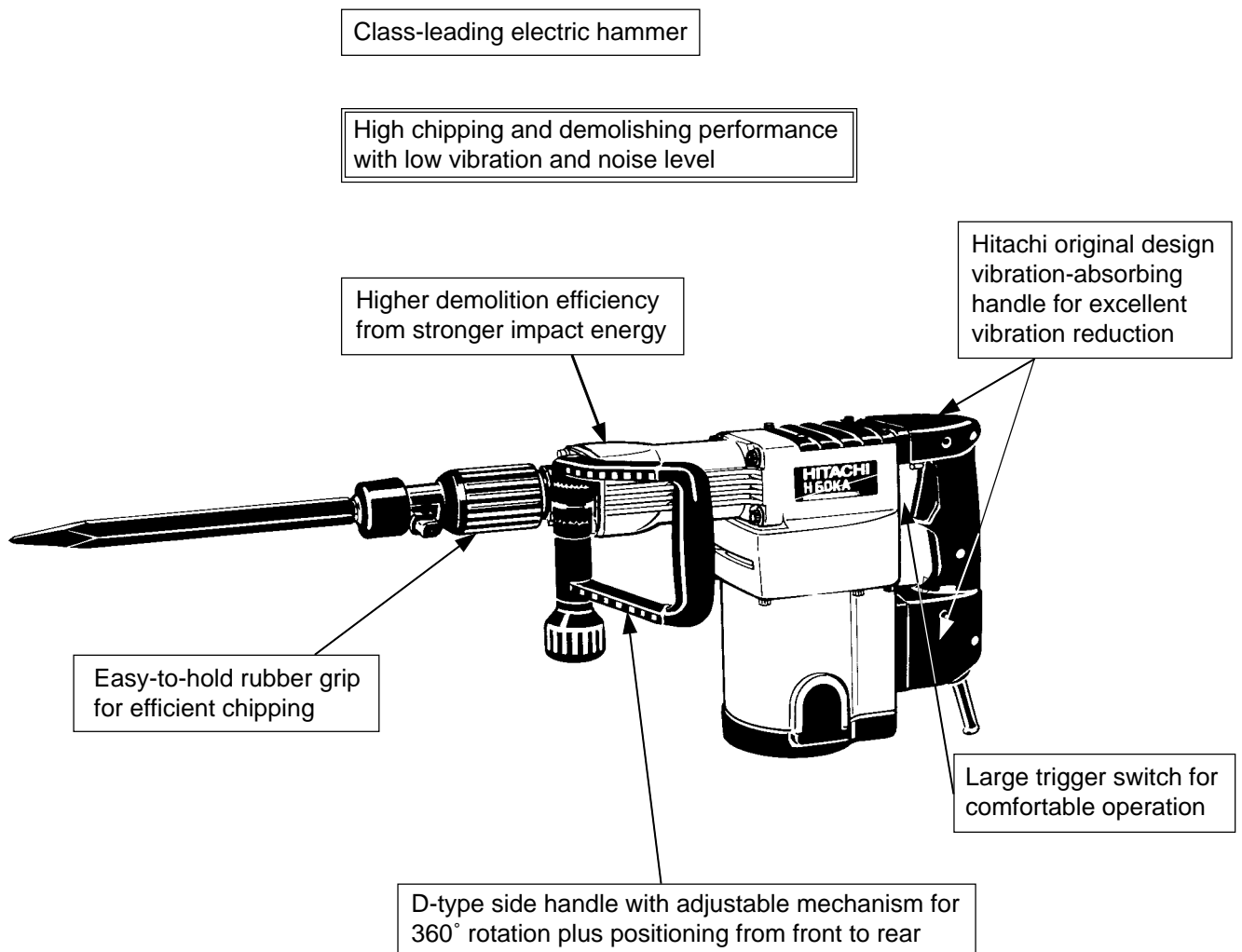

4-1. Selling Point Descriptions

4-1-1. High chipping and demolishing performance with low vibration and sound level

The chipping performance is approx. 1.3 times higher than that of similar competitors' products, thanks to the 25J impact energy and efficient striking. Even so, it produces low vibration and sound levels.

Maker • Model	Ratio of demolished weight (%)	Vibration level (m/s ²)	Sound level (dB(A))
HITACHI H 60KA	100	12.0	97
HITACHI H 55SA	80	20.5	105
(C)	(75)	(12.0)	(105)
(S)	(77)	(14.0)	(108)

(C) & (S) spec. is shown only for your reference, not for comparison.

4-1-2. Original design vibration-absorbing handle (Vibration-absorption is significantly improved)

Hitachi's original design vibration-absorbing handle minimizes vibration through the rolling and compression of four cylindrical rubber cushions on inclined surfaces. The spring constant factor is as low as that of the Models H 41SA, H 45SB2, H 41SC, H 45MA, H 60MA and H 60MB and the cushioning structure greatly reduces vibration.

4-1-3. D-type side handle with 360° rotation adjustable mechanism plus operation from front to rear

The D-type side handle can be adjusted over 360° rotation and also allows convenient positioning from front to rear. This side handle has a two-layer plastic construction (integral molding) made of nylon resin as the base and soft resin covering for a comfortable cushion grip.

4-1-4. Easy-to-handle rubber grip for efficient wall chipping

The rubber grip around the tool retainer allows secure gripping without slipping and easy positioning of the tool for efficient wall chipping.

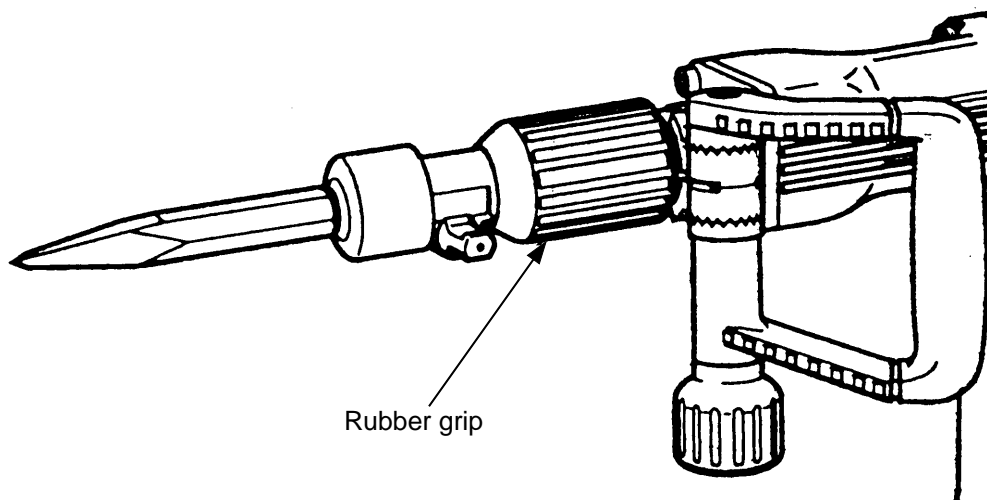

Fig. 1

5. SPECIFICATIONS

Item		H 60KA
Power source		Single-phase AC 50/60 Hz
Voltage (V)		110, 115, 230, 240
Motor type		AC single-phase series commutator motor
Insulation structure		Double insulation
Enclosure		Materials: Aluminum alloy die casting Nylon resin (Handle and tail cover) Paint: Silver green metallic, black
Switch		Trigger switch (with stopper)
Type of handles		D-shaped handle and side handle
Full-load current		12.4 A (110 V), 11.9 A (115 V), 6.0 A (230 V), 5.7 A (240 V)
Power input		1,300 W
Striking speed	No-load	1,970 /min.
	Full-load	1,600 /min.
Weight		Product: 11.0 kg (24.3 lbs.); excluding cord Packed: 18.5 kg (40.8 lbs.)
Packaging		Corrugated cardboard box with steel tool case
Standard accessories		<ul style="list-style-type: none"> • Bull point 300 mm (11-13/16") 1 • Hex. bar wrench (for M8) 1 • Dust cover 1 • Steel tool case 1 • Side handle 1

5-1. Optional Accessories

1. Demolition work

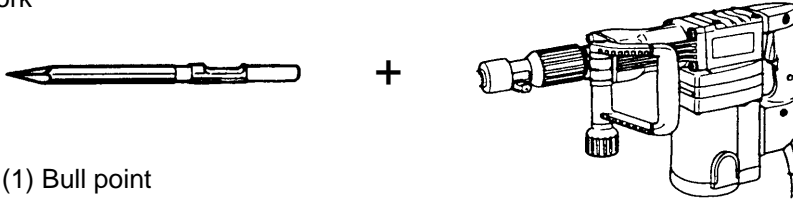

(1) Bull point

Overall length	Code No.
380 mm (14-31/32")	986948
450 mm (17-23/32")	986949

2. Grooving and chiseling work

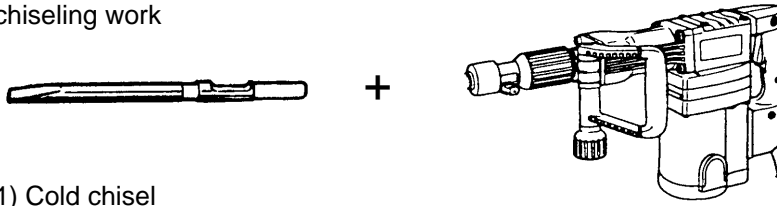

(1) Cold chisel

Overall length	Code No.
300 mm (11-13/16")	986952
380 mm (14-31/32")	986953
450 mm (17-23/32")	986954

3. Cutting and stripping work (asphalt cutting, etc.)

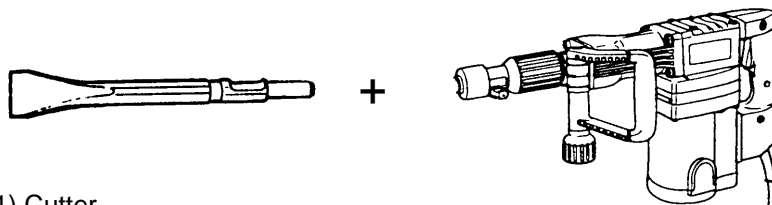

(1) Cutter

Width	Overall length	Code No.
50 mm (2")	400 mm (15-3/4")	986950
75 mm (2-61/64")	400 mm (15-3/4")	986951

4. Grease for impact drill

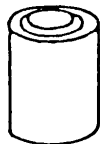

500 g (1.1 lbs.) Can

Code No. 980927

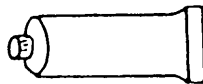

70 g (2.5 oz) Tube

Code No. 308471

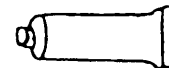

30 g (1 oz) Tube

Code No. 981840

(Note)

Code numbers listed above are subject to change. Please refer to periodic Technical News Bulletins.

6. COMPARISONS WITH SIMILAR PRODUCTS

6-1. Specification Comparisons

Maker		HITACHI		(C)	(S)
Model name		H 60KA	H 55SA		
Power input	W	1,300	1,140	(940)	(1,050)
Full-load impact rate	/min.	1,600	1,450	(2,000)	(2,000)
Dimensions	Length	mm 576 (22-43/64")	563 (22-5/32")	(470) (18-1/2")	(675) (26-9/16")
	Height	mm 280 (11-1/32")	281 (11-1/16")	(250) (9-27/32")	(186) (7-21/64")
	Width	mm 121 (4-51/64")	110 (4-21/64")	— (—)	— (—)
Striking energy per stroke	J	25.0	16.0	(14.2)	(16.4)
Insulation structure	—	Double insulation	Double insulation	(Double insulation)	(Double insulation)
No-load noise level	dB(A)	85	86	—	—
Sound power level	dB(A)	97	105	(105)	(108)
Vibration level	m/s ²	12.0	20.5	(12.0)	14.0
Weight (without cord)	kg	11.0 kg (24.3 lbs.)	9.5 kg (20.9 lbs.)	(9.1 kg) (20.1 lbs.)	(10.0 kg) (22.0 lbs.)

(C) & (S) spec. is shown only for your reference, not for comparison.

6-2. Demolition Performance

The data shown in Fig. 2 are obtained in actual factory tests, and are for reference only. Demolished amount may vary in accordance with operating conditions, operator skill, etc.

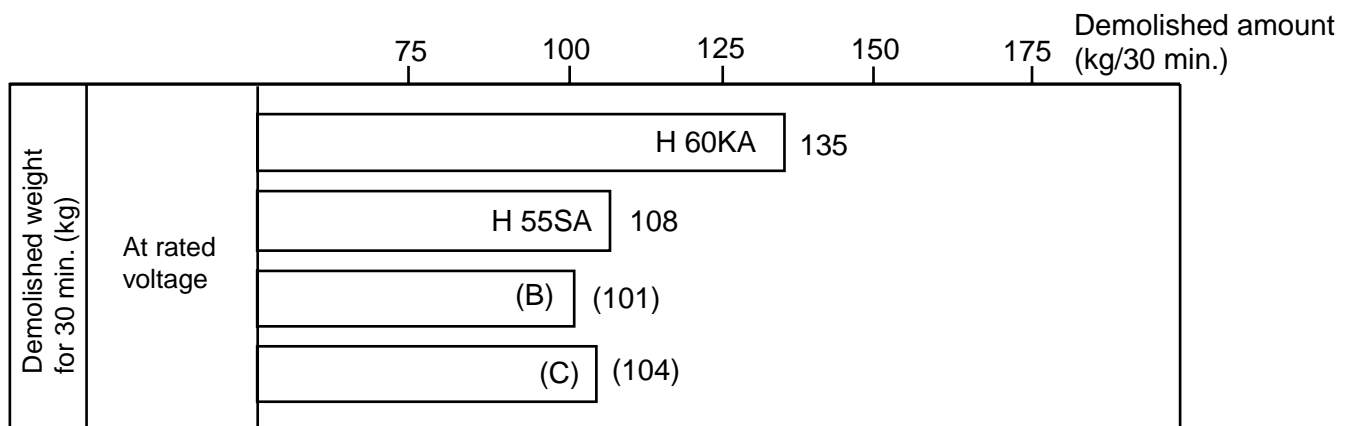

Fig. 2

7. PRECAUTIONS IN SALES PROMOTION

In the interest of promoting the safest and most efficient use of the Model H 60KA Electric Hammer by all of our customers, it is very important that at the time of sale the salesperson carefully ensures that the buyer seriously recognizes the importance of the contents of the Handling Instructions, and fully understands the meaning of the precautions listed on the Caution Plate attached to each tool.

7-1. Handling Instructions

Although every effort is made in each step of design, manufacture and inspection to provide protection against safety hazards, the dangers inherent in the use of any electric tool cannot be completely eliminated. Accordingly, general precautions and suggestions for the use of electric power tools, and specific precautions and suggestions for the use of the Electric Hammer are listed in the Handling Instructions to enhance the safe, efficient use of the tool by the customer. Salespersons must be thoroughly familiar with the contents of the Handling Instructions to be able to offer appropriate guidance to the customer during sales promotion.

7-2. Caution Plate

The Model H 60KA unit is provided with a Caution Plate (illustrated below) which lists basic safety precautions in use. Carefully ensure that the customer fully understands and follows these precautions before using the tool.

For Australia



7-3. Grease Replacement

The striking portion and the speed reduction portion of the Model H 60KA respectively use different types of grease. Grease replacement is required if the unit is disassembled for maintenance or O-rings become damaged or worn as described in 7-4.

The striking portion uses special grease. If the striking portion (inside the cylinder case and crank case) is disassembled, thoroughly remove all of the old grease from each part. On reassembly, insert 60 g (2.1 oz) of new grease into the crank case (connecting rod side). Do not exceed the designated amount of grease. Excessive grease insertion may cause reduced striking performance.

The speed reduction portion (inside the gear cover) uses Hitachi Motor Grease No. 29 (Code No. 930035). The proper supply volume is 40 g (1.4 oz). Never use the striking portion special grease in the speed reduction portion. Special grease would leak into the motor portion and cause subsequent trouble.

7-4. O-Ring Replacement

The O-rings (mounted on the striker and piston) are extremely important to ensure adequate sealing of the air pressure. Although the O-rings are made of special rubber to give them a long service life, they do nonetheless become worn, and should be replaced by new ones periodically depending on frequency of use of the tool. With average use, it is recommended that the O-rings be replaced at least every six months to ensure maximum effectiveness.

8. REFERENCE INFORMATION

Structure:

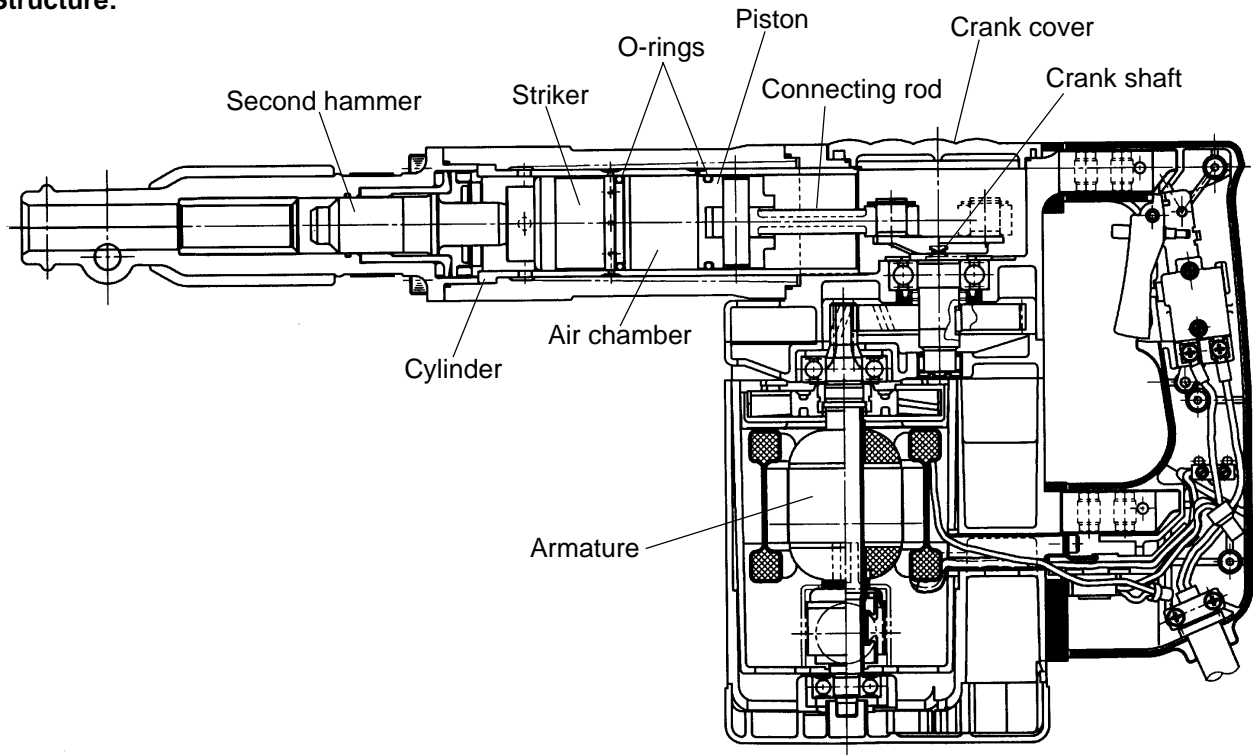

Fig. 3

8-1. Striking Operation

The rotation of the armature is transferred to the crank shaft and connecting rod, which in turn cause the piston to reciprocate inside the cylinder. As the piston reciprocates, the changing air pressure inside the air chamber between the piston and the striker causes the striker to continuously strike against the end of the second hammer. At the same time, the air-cushion effect within the air chamber absorbs the impact of the second hammer. Should the air escape from the air chamber, the air-cushion effect would cease, and the impact energy would not be absorbed. Accordingly, the O-rings mounted on the striker and piston play an extremely important role in sealing the air within the air chamber.

8-2. Idling-Proof Mechanism

When the bull point is released from the concrete surface, the second hammer moves to the position illustrated in Fig. 4, and the striker moves out of striking position. When this occurs, the air holes are opened and the pressure within the air chamber remains unchanged even though the piston continues to reciprocate, thereby preventing striking operation.

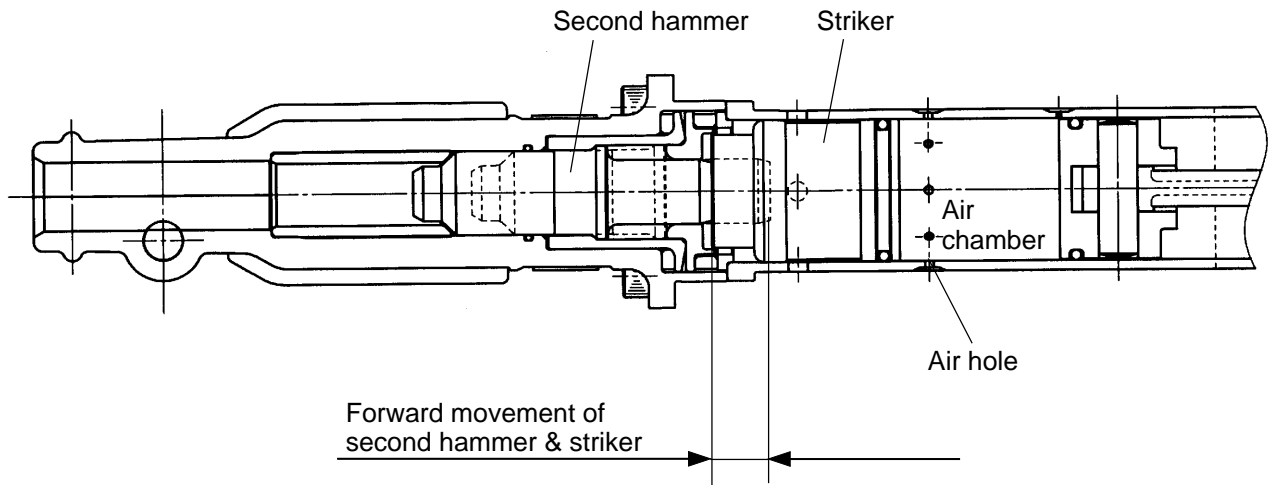

Fig. 4

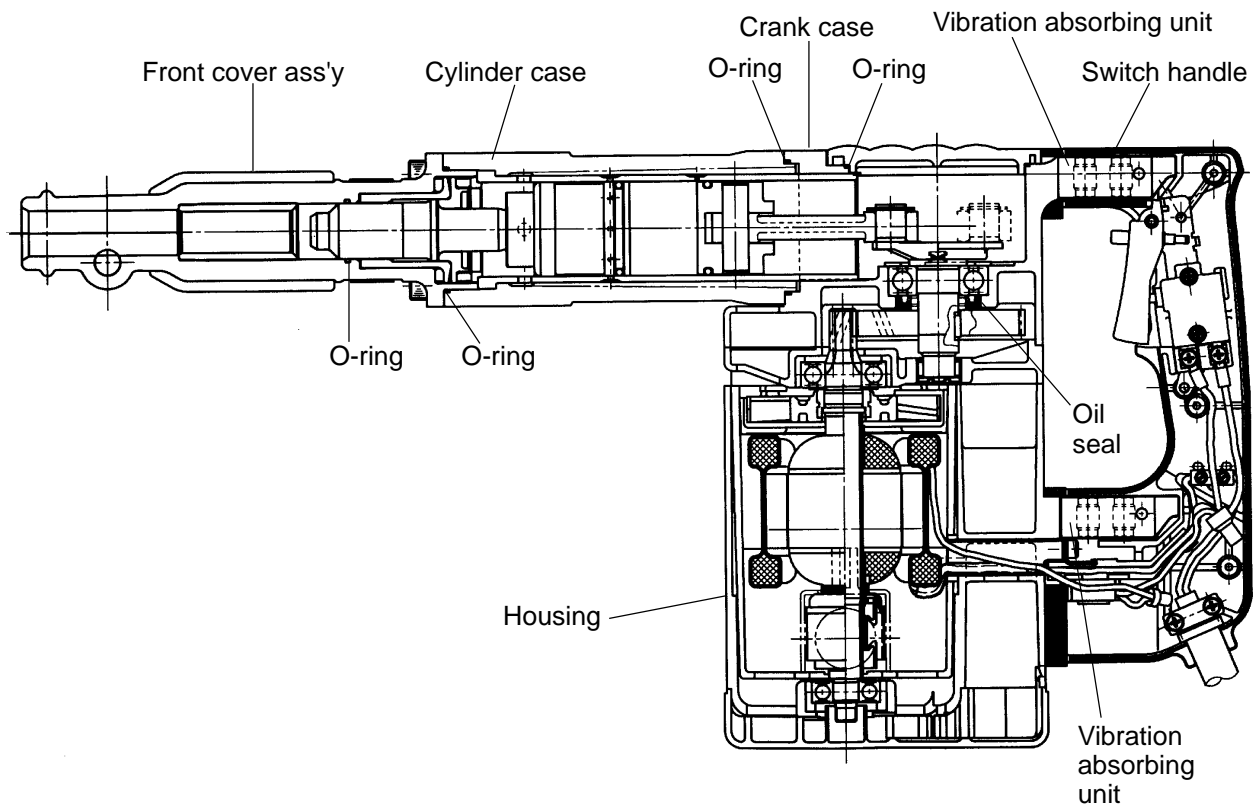

Fig. 5

8-3. Sealed and Dustproof Construction

The crank case and cylinder case are sealed by four O-rings, and an oil seal which serve to prevent leakage of the grease, as well as to prevent dust and dirt from entering the mechanism.

8-4. Vibration Absorbing Construction

Hitachi original, innovative units which absorb vibration are installed between the switch handle and the crank case and between the switch handle and the housing. As a result, the amount of vibration transmitted from the main body to the arms of the operator is considerably less in comparison with conventional hammers.

Construction of vibration absorbing unit:
 The main body (crank case and housing) and the handle are connected through four cylindrical rubbers (handle dampers). Vibration is absorbed by the rolling and compression of the four rubbers on inclined surfaces. Because the vibration absorbing unit has non-linear spring characteristics, its spring constant factor is lower than that of the conventional shearing rubber type vibration-absorbing construction, and it provides significantly higher efficiency in minimizing vibration. In addition, the interlocking slotted groove and cylindrical convex portions at the center prevent the handle from being disconnected by twisting or pulling, a common problem with conventional hammers.

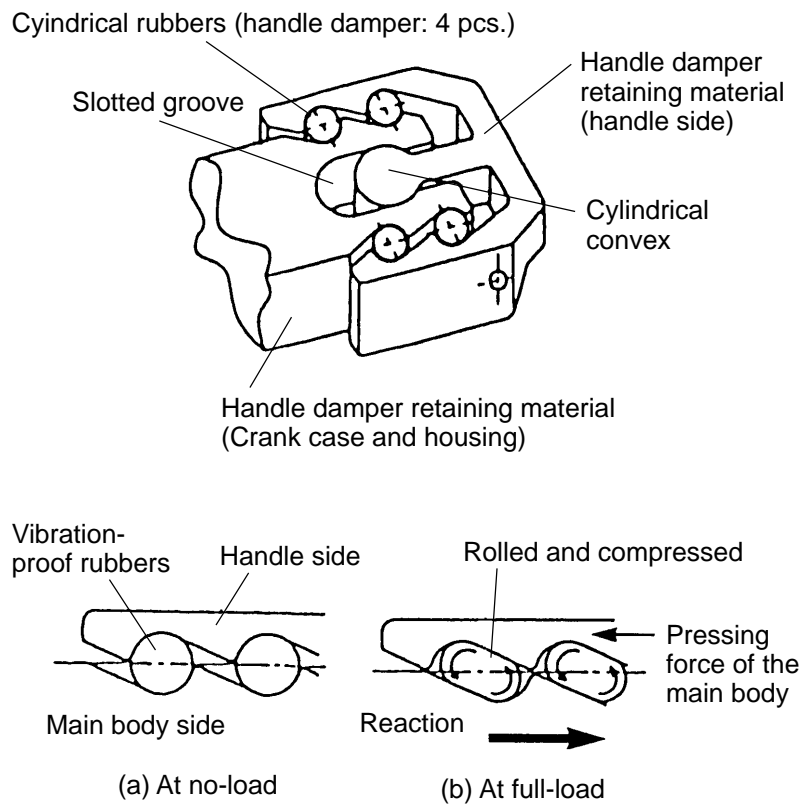

Fig. 6

8-5. Tool Retainer (Fig. 7)

- Installing dust cover

Always install the dust cover in the tool.

Insert the dust cover until it lies flush in the groove.

- Installing tool

- (1) Clean, then smear the tool shank with the grease provided.
- (2) Slide the stop lever in the direction of arrow (A) and rotate it 180°. Turn the notch of the tool shank downward and insert it fully into the hexagonal hole of the front cover ass'y.
- (3) Turn the stop lever and align the front cover mark with the stop lever mark to secure.

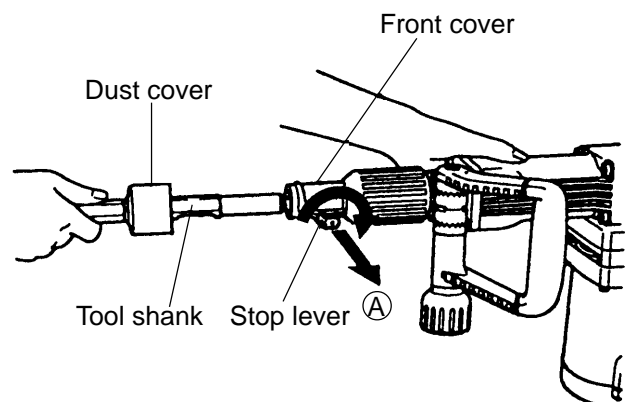

Fig. 7

8-6. Side Handle

The side handle can be adjusted by 360° rotation and also allows operation from front to rear. Loosen the handle by turning the grip in (A) direction and adjust the handle to a convenient position. Turn the grip in (B) direction to fix the side handle (Fig. 8).

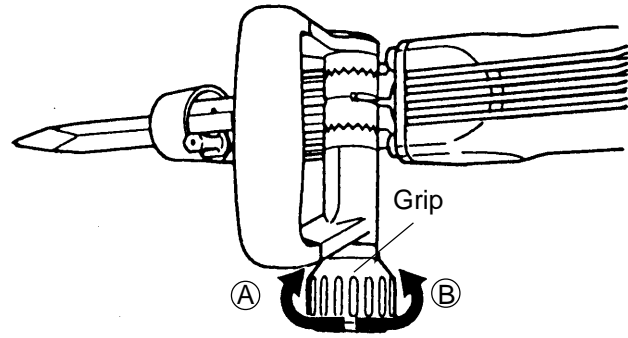

Fig. 8

9. REPAIR GUIDE

9-1. Precautions and Suggestions for Disassembly and Reassembly of the Main Body

The numbers in **[Bold]** correspond to the item numbers in the Parts List and exploded assembly diagrams.

9-1-1. Disassembly

- Piston and striker disassembly

Remove the Hex. Socket Hd. Bolt (W/Flange) M8 x 35 **[20]** fixing the Cylinder Case **[19]**, and disassemble the Cylinder Case **[19]** from the Crank Case **[28]**. As the Piston **[25]** remains in the Crank Case **[28]** side, remove the Retaining Ring for D14 Shaft **[27]** to remove the Connecting Rod **[26]** from the Crank Shaft **[33]**.

The Striker **[22]** can be removed by tapping the Cylinder Case **[19]** lightly with a plastic hammer. If it does not come out easily, push the disassembled Piston **[25]** with the Connecting Rod **[26]** back into the Cylinder, and pull them apart again quickly. The Striker can come out at the same time.

- First gear and crank shaft disassembly

Remove the grease from the Connecting Rod **[26]** side and the First Gear **[44]** side of the Crank Case **[28]**.

Remove the two Seal Lock Hex. Socket Hd. Bolts M5 x 14 **[35]** fixing the Bearing Cover **[36]**. Then place the Connecting Rod **[26]** side of the Crank Case **[28]** downward on a workbench and apply pressure on the end surface of the Crank Shaft **[33]** with a hand press to remove the First Gear **[44]** and the Crank Shaft **[33]**

(Fig. 9). Before removing them, make sure that the two Seal Lock Hex. Socket Hd. Bolts M5 x 14 **[35]** fixing the Bearing Cover **[36]** are removed.

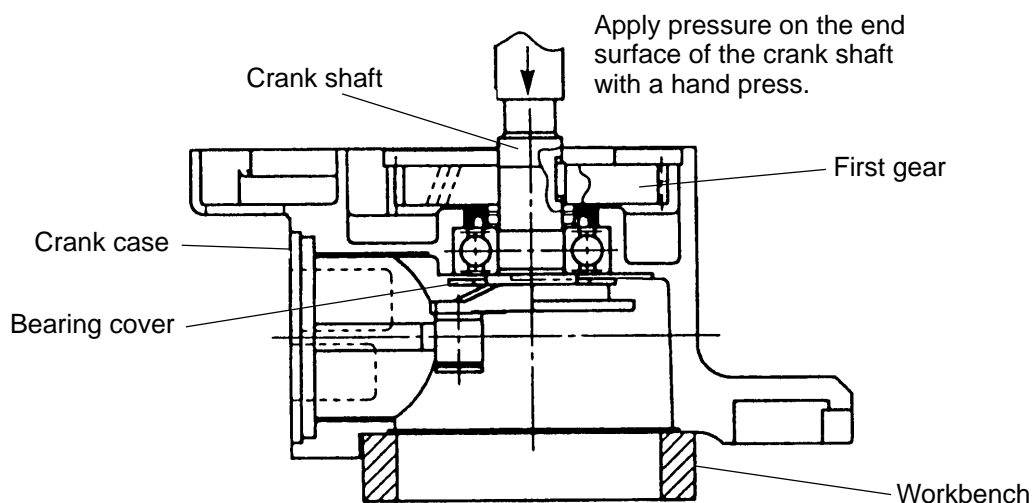

Fig. 9

- Stop lever disassembly

Pull the Stop Lever [3] in the direction of the arrow, rotate it a little and slide the end surface of the stop lever over the flange end surface of the Front Cover Ass'y [9]. Rotate the spring case so that the hole of the Spring Case [4] is adjusted to the position of the Needle Roller D4 x 20 [5] and remove the needle roller. Then, the Stop Lever [3], Stopper Sleeve [7] and the Stopper Spring [6] can be taken off.

Slide the end surface of the stop lever over the flange of the front cover ass'y

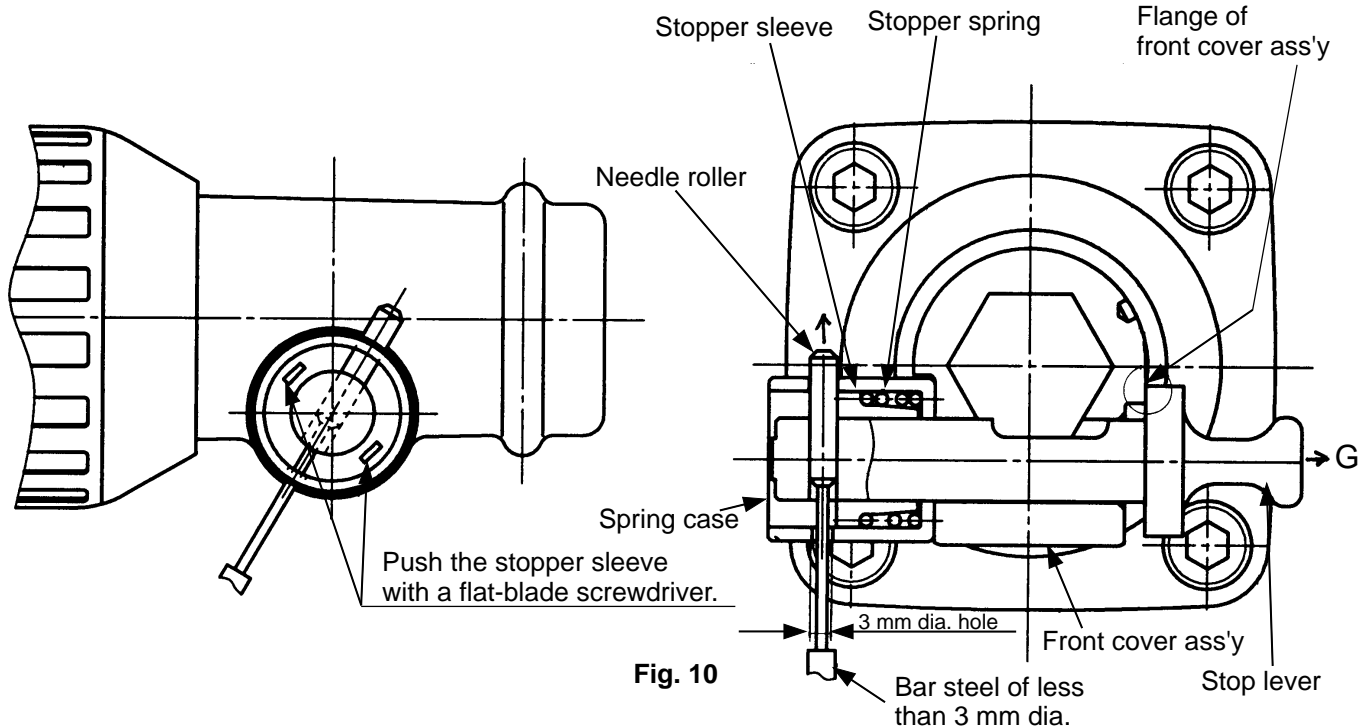

Fig. 10

9-1-2. Reassembly

Reassembly can be accomplished by following the disassembly procedure in reverse.

However, special attention should be given to the following items.

- First gear and crank shaft reassembly

Press-fit the Ball Bearing [37] in the Crank Case [28] and fix the Bearing Cover [36] with the two Seal Lock Hex. Socket Hd. Bolts M5 x 14 [35]. Press-fit the Crank Shaft [33]. Then press-fit Distance Ring (C) [39] and mount the Oil Seal [38]. Put the Feather Key 3 x 3 x 10 [34] into the groove of the Crank Shaft [33] and press-fit the First Gear [44] with a suitable tool while holding the flat portion of the Crank Shaft [33] with a steel bar. Before press-fitting, make sure that the Feather Key 3 x 3 x 10 [34] fits in the key groove of the First Gear [44] (Fig. 11).

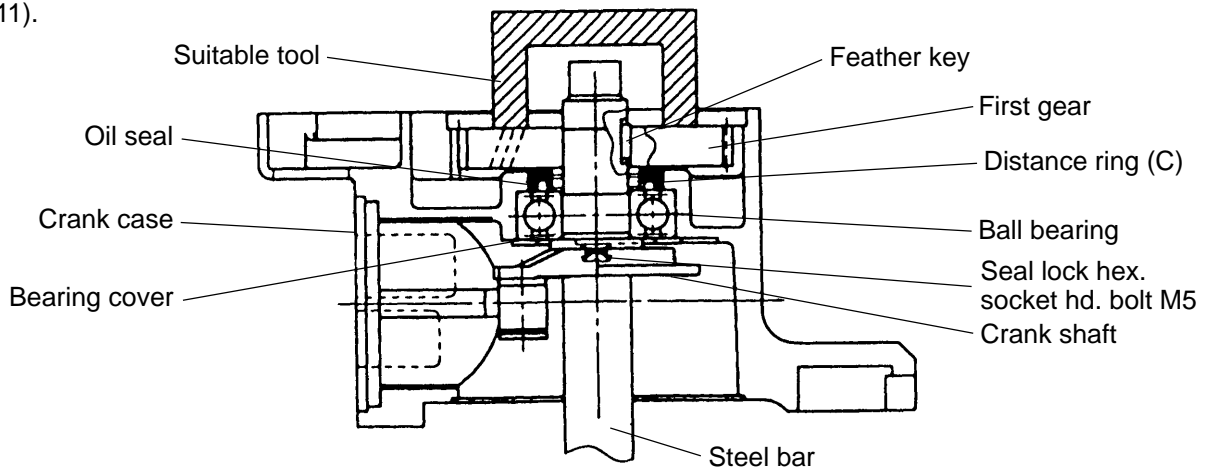

Fig. 11

- Lubrication

Apply special grease (grease for electric impact drills) to the inner circumference of the Connecting Rod [26], O-Rings (A) [23] in the Striker [22] and in the Piston [25], the sliding portion of the Second Hammer [14], the Oil Seal [38], the Damper [16], Damper (B) [12], the Damper Washer [17]. Seal 60 g of the special grease into the Crank Case [28] (Connecting Rod [26] side). Apply Hitachi Motor Grease No. 29 to Needle Bearing (A) [45], the pinion portion of the Armature Ass'y [55]. Seal 40 g of the Hitachi Motor Grease No. 29 into the Crank Case [28] (First Gear [44] side).

- Oil seals

Be very careful not to damage the O-Ring [32] in the Crank Cover [31], O-Rings (A) [23] in the Striker [22] and in the Piston [25], the Oil Seal [38] in the Crank Case [28], the O-Ring [21] on the Cylinder Case [19], the O-Ring [18] on the Front Cover Ass'y [9], the O-Ring [11] in the Front Cover Ass'y [9].

- Retainer reassembly

Apply Mollub alloy K#777-1 lubricant to the sliding part of the Stop Lever [3] before assembling. As shown in Fig. 12, mount the stop lever end surface on the flange of the Front Cover Ass'y [9] and push the Stopper Sleeve [7] with a flat-blade screwdriver to contract the Stopper Spring [6]. Adjust the holes of the stop lever and Spring Case [4], and insert the Needle Roller D4 x 20 [5].

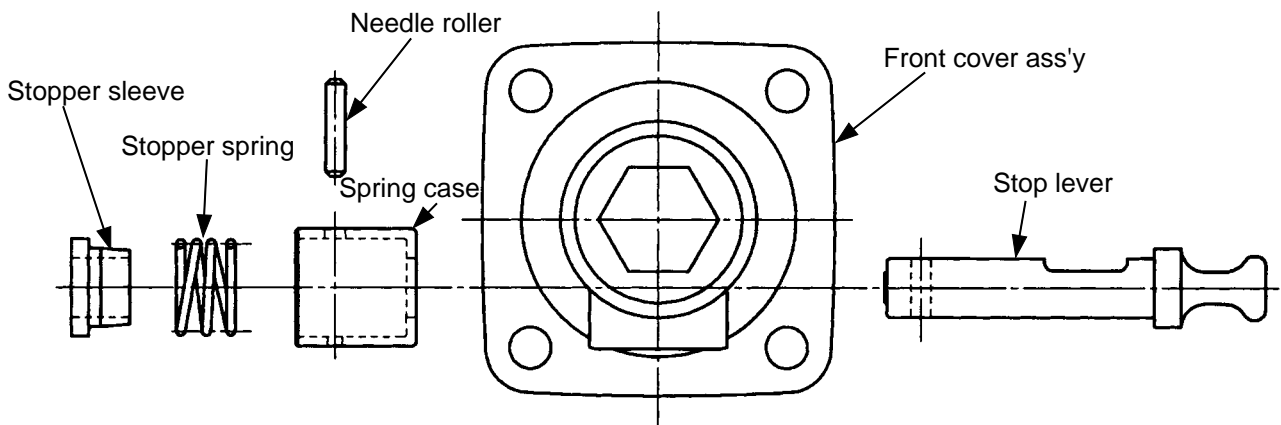

Fig. 12

9-1-3. Screw locking agent TB1401

Apply screw locking agent TB1401 to all hex. socket hd. bolts M5 and M6. (As the hex. socket hd. bolts for M8 that secure the front cover ass'y and the hex. socket hd. bolts (w/flange) for M8 that secure the cylinder case are special bolts, they cannot be re-used if removed. Use fresh service parts only.)

Caution: If bolts are loosened by vibration, it could cause damage to the hammer body. Ensure without fail that screw locking agent is applied to threaded portions prior to reassembly.

9-1-4. Tightening torque

- | | |
|---|---|
| (1) Hex. socket hd. bolts M5 | $7.84 \begin{smallmatrix} +1.96 \\ 0 \end{smallmatrix} \text{ N}\cdot\text{m}$ ($80 \begin{smallmatrix} +20 \\ 0 \end{smallmatrix} \text{ kgf}\cdot\text{cm}$, $69.4 \begin{smallmatrix} +17.4 \\ 0 \end{smallmatrix} \text{ in}\cdot\text{lbs.}$) |
| (2) Attached bolts of handle
(Hex. socket hd. bolts M5 x 12) | $4.94 \begin{smallmatrix} +1.96 \\ 0 \end{smallmatrix} \text{ N}\cdot\text{m}$ ($50 \begin{smallmatrix} +20 \\ 0 \end{smallmatrix} \text{ kgf}\cdot\text{cm}$, $43.4 \begin{smallmatrix} +17.4 \\ 0 \end{smallmatrix} \text{ in}\cdot\text{lbs.}$) |
| (3) Hex. socket hd. bolts M6 | $9.80 \begin{smallmatrix} +1.96 \\ 0 \end{smallmatrix} \text{ N}\cdot\text{m}$ ($100 \begin{smallmatrix} +20 \\ 0 \end{smallmatrix} \text{ kgf}\cdot\text{cm}$, $86.8 \begin{smallmatrix} +17.4 \\ 0 \end{smallmatrix} \text{ in}\cdot\text{lbs.}$) |
| (4) Tapping screws D4 | $19.6 \pm 0.49 \text{ N}\cdot\text{m}$ ($20 \pm 5 \text{ kgf}\cdot\text{cm}$, $17.4 \pm 4.3 \text{ in}\cdot\text{lbs.}$) |
| (5) Tapping screws D5 | $2.94 \pm 0.49 \text{ N}\cdot\text{m}$ ($30 \pm 5 \text{ kgf}\cdot\text{cm}$, $26.0 \pm 4.3 \text{ in}\cdot\text{lbs.}$) |
| (6) Attached bolts of front cover ass'y
(Hex. socket hd. bolts M8 x 25) | $39.2 \pm 0.98 \text{ N}\cdot\text{m}$ ($400 \pm 10 \text{ kgf}\cdot\text{cm}$, $347.2 \pm 8.7 \text{ in}\cdot\text{lbs.}$) |
| (7) Attached bolts of cylinder case
(Hex. socket hd. bolts (W/flange) M8 x 35) | $19.6 \begin{smallmatrix} +1.96 \\ 0 \end{smallmatrix} \text{ N}\cdot\text{m}$ ($200 \begin{smallmatrix} +20 \\ 0 \end{smallmatrix} \text{ kgf}\cdot\text{cm}$, $173.6 \begin{smallmatrix} +17.4 \\ 0 \end{smallmatrix} \text{ in}\cdot\text{lbs.}$) |

9-1-5. Internal wiring

- Wiring diagram

- (1) For products with noise suppressor

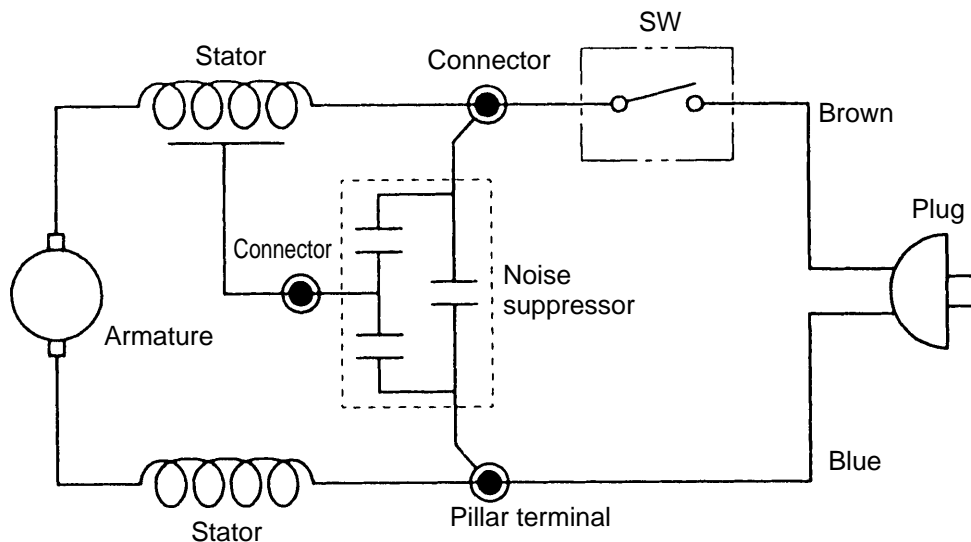

Fig. 13

(2) For products without noise suppressor

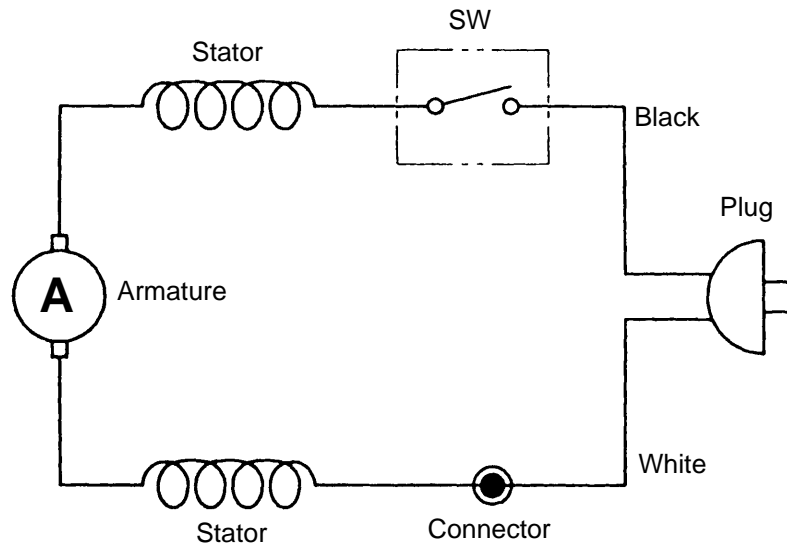

Fig. 14

• Schematic diagram

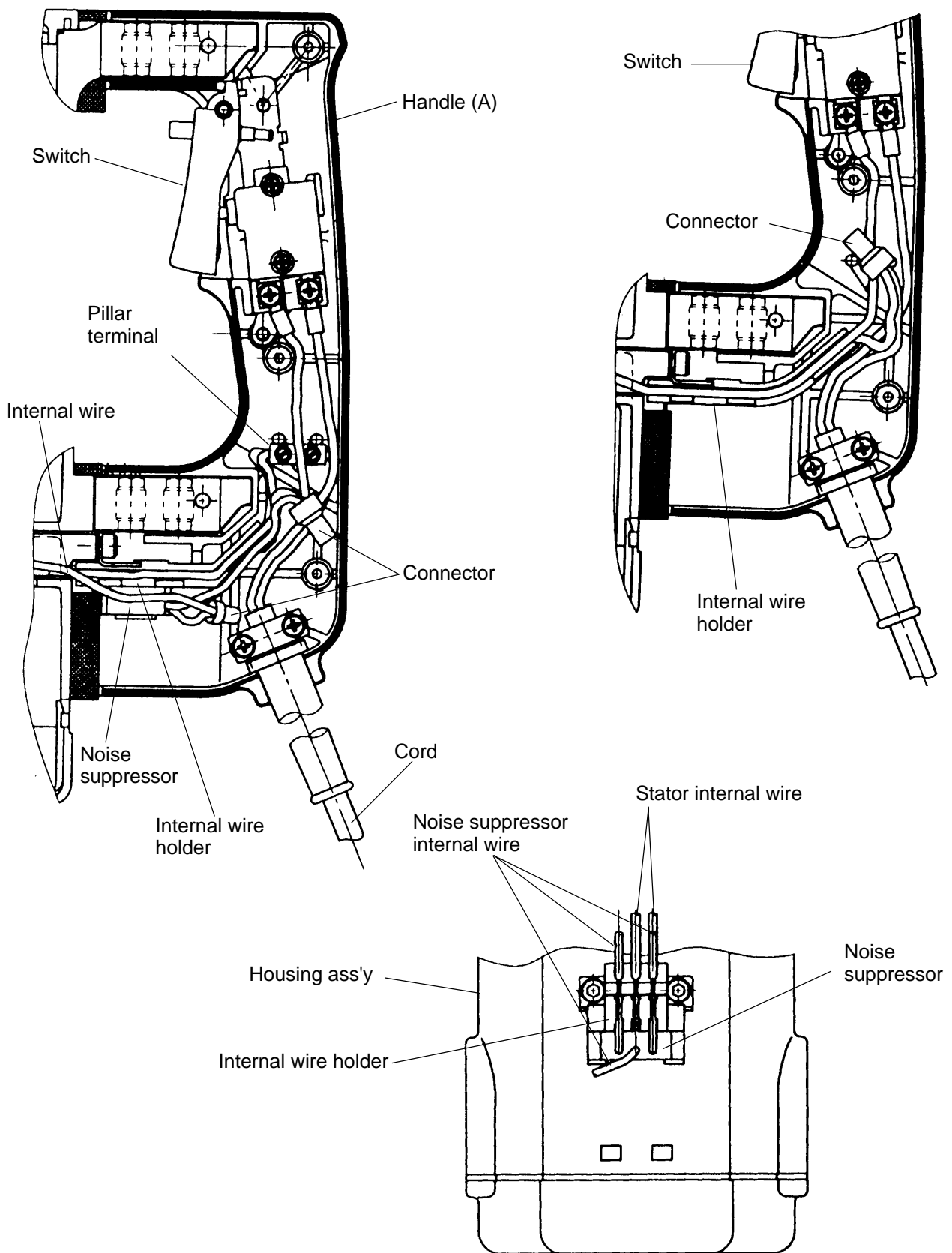

Fig. 15

9-1-6. Insulation tests

On completion of disassembly and repair, measure the insulation resistance and dielectric strength.

Insulation resistance: 7 MΩ or more with DC 500 V Megohm Tester

Dielectric strength: AC 4000 V/1 minute, with no abnormalities ... 220 V – 240 V
(and 110 V for U.K. products)

AC 2500 V/1 minute, with no abnormalities ... 110 V – 127 V
(except U.K. products)

9-1-7. No-load current value

After no-load operation for 30 minutes, the no-load current value should be as follows:

Voltage (V)	110	220	230	240
Current (A) (Max.)	7.5	7.2	3.6	3.5

10. STANDARD REPAIR TIME (UNIT) SCHEDULES

MODEL	Variable		10	20	30	40	50	60 min.
	Fixed							
H 60KA		Work Flow						
				Switch (B) Cord			Gear Cover Needle Bearing Armature Ass'y Ball Bearing (6201VV) Ball Bearing (608VV) Washer (A) Washer (B)	Housing Ass'y Stator Ass'y
	General Assembly				Handle (A) Handle (B) Transatory Unit		Crank Shaft Feather Key (4 x 4 x 10) Ball Bearing (6203DD) O-ring (S-40) Oil Seal First Gear	Crank Case
		Stop Lever Ass'y Stop Lever Spring Case Needle Roller Stopper Spring Stopper Sleeve		Front Cover Ass'y Sleeve O-ring (S-26) Damper (B) Second Hammer Hammer Holder (B) Damper Damper Washer O-ring (S-56)				
					Striker O-ring x 2 Piston Pin Connecting Rod		Cylinder Case	

Assembly Diagram for H 60KA

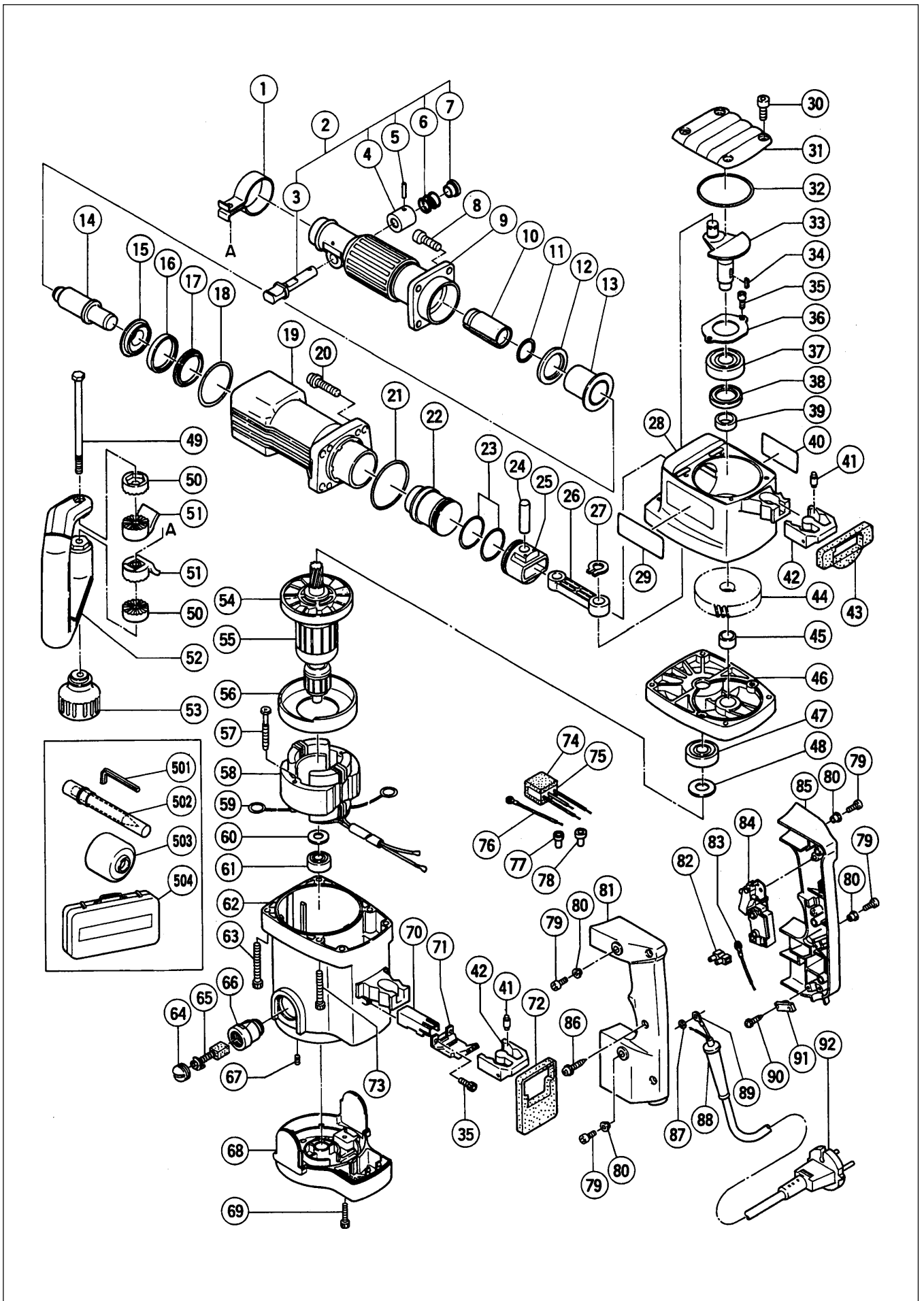

PARTS

H 60KA

ITEM NO.	CODE NO.	DESCRIPTION	NO. USED	REMARKS	
1	317-104	BAND	1		
2	310-891	STOP LEVER ASS'Y	1	INCLUD.3-7	
3	302-095	STOP LEVER	1		
4	993-241	SPRING CASE	1		
5	943-364	NEEDLE ROLLER D4X20	1		
6	302-096	STOPPER SPRING	1		
7	993-243	STOPPER SLEEVE	1		
8	985-479	SEAL LOCK HEX. SOCKET HD. BOLT M8X25	4		
9	319-109	FRONT COVER ASS'Y	1	INCLUD.10	
10	319-110	SLEEVE	1		
11	872-470	O-RING (S-26)	1		
12	317-094	DAMPER (B)	1		
13	317-092	HAMMER HOLDER (B)	1		
14	319-111	SECOND HAMMER	1		
15	317-091	HAMMER HOLDER (A)	1		
16	317-093	DAMPER	1		
17	317-095	DAMPER WASHER	1		
18	317-119	O-RING (S-56)	1		
19	317-085	CYLINDER CASE	1		
20	990-083	HEX. SOCKET HD. BOLT (W/FLANGE) M8X35	4		
21	956-996	O-RING (1AS-60)	1		
22	301-510	STRIKER	1		
23	985-454	O-RING (A) (FPM810)	2		
24	301-509	PISTON PIN	1		
25	317-084	PISTON	1		
26	317-082	CONNECTING ROD	1		
27	939-543	RETAINING RING FOR D14 SHAFT (10 PCS.)	1		
28	317-083	CRANK CASE	1		
29		HITACHI LABEL	1		
30	990-079	SEAL LOCK HEX. SOCKET HD. BOLT M5X16	4		
31	317-079	CRANK COVER	1		
32	993-195	O-RING	1		
33	317-078	CRANK SHAFT	1		
34	940-533	FEATHER KEY 3X3X10	1		
35	984-509	SEAL LOCK HEX. SOCKET HD. BOLT M5X14	4		
36	985-443	BEARING COVER	1		
37	620-4DD	BALL BEARING 6204DDCMPS2L	1		
38	995-403	OIL SEAL	1		
39	995-402	DISTANCE RING (C)	1		
40		NAME PLATE	1		
41	310-124	HANDLE DAMPER	8		
42	310-123	TRANSATORY UNIT	2		
43	317-101	HANDLE PACKING (A)	1		
44	317-080	FIRST GEAR	1		
45	985-442	NEEDLE BEARING (A) (BK1512)	1		
46	317-081	GEAR COVER ASS'Y	1	INCLUD.45	
47	620-3DD	BALL BEARING 6203DDCMPS2L	1		
48	992-841	BEARING WASHER	1		
49	317-107	BOLT M8	1		
50	317-106	HANDLE HOLDER (B)	2		
51	317-105	HANDLE HOLDER (A)	2		

PARTS

H 60KA

ITEM NO.	CODE NO.	DESCRIPTION	NO. USED	REMARKS	
52	317-103	SIDE HANDLE ASS'Y	1	INCLUD.1,49-51,53	
53	317-108	GRIP	1		
54	996-370	FAN	1		
* 55	360-486C	ARMATURE ASS'Y 110V-115V	1	INCLUD.54	
* 55	360-486E	ARMATURE ASS'Y 230V	1	INCLUD.54	
* 55	360-486F	ARMATURE ASS'Y 240V	1	INCLUD.54	
56	305-610	FAN GUIDE	1		
57	953-121	HEX. HD. TAPPING SCREW D5X50	2		
* 58	340-430C	STATOR ASS'Y 110V	1	INCLUD.59	
* 58	340-430E	STATOR ASS'Y 230V	1	INCLUD.59	
* 58	340-430F	STATOR ASS'Y 240V	1	INCLUD.59	
59	945-932	BRUSH TERMINAL	2		
60	944-954	BEARING WASHER	1		
61	620-1DD	BALL BEARING 6201DDCMPS2L	1		
62	317-128	HOUSING ASS'Y	1	INCLUD.66,67	
63	301-567	SEAL LOCK HEX. SOCKET HD. BOLT M6X55	4		
64	940-540	BRUSH CAP	2		
65	999-074	CARBON BRUSH (AUTO STOP TYPE) (1 PAIR)	2		
66	956-984	BRUSH HOLDER	2		
67	938-477	HEX. SOCKET SET SCREW M5X8	2		
68	317-086	TAIL COVER	1		
69	317-245	SEAL LOCK HEX. SOCKET HD. BOLT M5X22	2		
70	317-099	SLEEVE	1		
71	310-424	INTERNAL WIRE HOLDER	1		
72	317-102	HANDLE PACKING (B)	1		
73	986-940	SEAL LOCK HEX. SOCKET HD. BOLT M6X45	2		
74	317-492	SUPPORT (B)	1		
75	994-273	NOISE SUPPRESSOR	1		
76	990-861	INTERNAL WIRE	1		
77	959-140	CONNECTOR 50091 (10 PCS.)	1		
78	959-141	CONNECTOR 50092 (10 PCS.)	1		
79	991-690	SEAL LOCK HEX. SOCKET HD. BOLT M5X12	4		
80	991-711	DISTANCE PIECE (B)	4		
81	317-097	HANDLE (B)	1		
82	938-307	PILLAR TERMINAL	1		
83	981-974	INTERNAL WIRE	1		
84	306-143	SWITCH (B) (1P SCREW TYPE) W/LOCK	1		
85	317-096	HANDLE (A)	1		
86	307-028	TAPPING SCREW (W/FLANGE) D4X25 (BLACK)	3		
87	949-423	WASHER M4 (10 PCS.)	1		
* 88	938-051	CORD ARMOR D10.1	1		
* 88	953-327	CORD ARMOR D8.8	1		
* 89	992-810	TERMINAL	1		
* 89	980-063	TERMINAL	1	FOR AUS,GBR (110V)	
90	984-750	TAPPING SCREW (W/FLANGE) D4X16	2		
* 91	960-266	CORD CLIP	1		
* 91	981-987Z	CORD CLIP	1	FOR SUI	
* 92	500-390Z	CORD	1	(CORD ARMOR D10.1)	
* 92	500-446Z	CORD	1	(CORD ARMOR D10.1) FOR GBR (230V)	
* 92	500-408Z	CORD	1	(CORD ARMOR D10.1) FOR AUS	
* 92	500-465Z	CORD	1	(CORD ARMOR D8.8) FOR GBR (110V)	

* : ALTERNATIVE PARTS

5 - 00

